

The Modular Modeling of Biological Networks using Transcription Rates

Austin Che & Bogdan Fedeles

BE.400

December 12, 2002

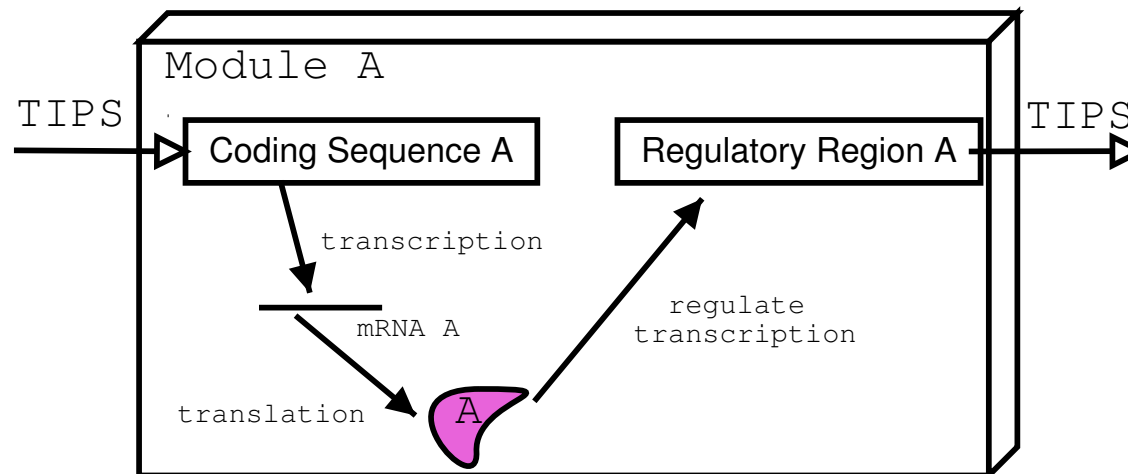

Outline

An Approach based on Transcription Rates

- Why transcription rates?
- Modularity

Example Networks

- Phage λ
- MAPK signaling pathway
- Synthetic 2-bit adder

Proposed Methodology

- Measuring TIPS
- Library of modules

Conclusions

Why Transcription Initiation Rates?

Advantages

- Transcription Initiations Per Second (TIPS) as universal input/output
- Everything is transcribed at some point
- Initiation events is independent of sequence and length
- Rates are a quantitative measure

Disadvantages

- Hard to measure
- Little data available
- No information about non-transcriptional events (protein-protein interactions)

Modeling Approach

Modularity

- Inputs/Outputs measured in TIPS
- Module treated as black box
 - ▷ *Module specified completely by transfer curve*

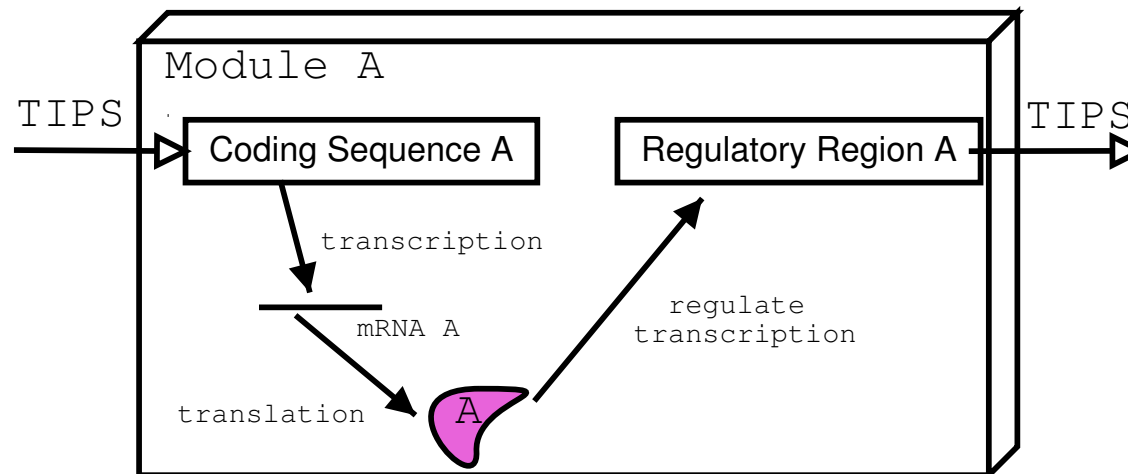

Simulating Network of Modules

On each iteration, outputs for each module are set based on inputs and transfer curve.

Example of transfer curve functions

- Minimum over all inputs
- Random (Fourier series)

$$f(x) = \sum_{i=0}^n c_i \cos(\omega i x + \phi_i)$$

- Linear

$$f(x_1, x_2, \dots, x_n) = c_0 + \sum_{i=1}^n c_i x_i$$

- Sigmoidal

$$f(x) = a \cdot (\tanh((x - m)/w) + 1)$$

Some inputs and outputs are “pseudo-TIPS” for purpose of simulation

Bacteriophage λ

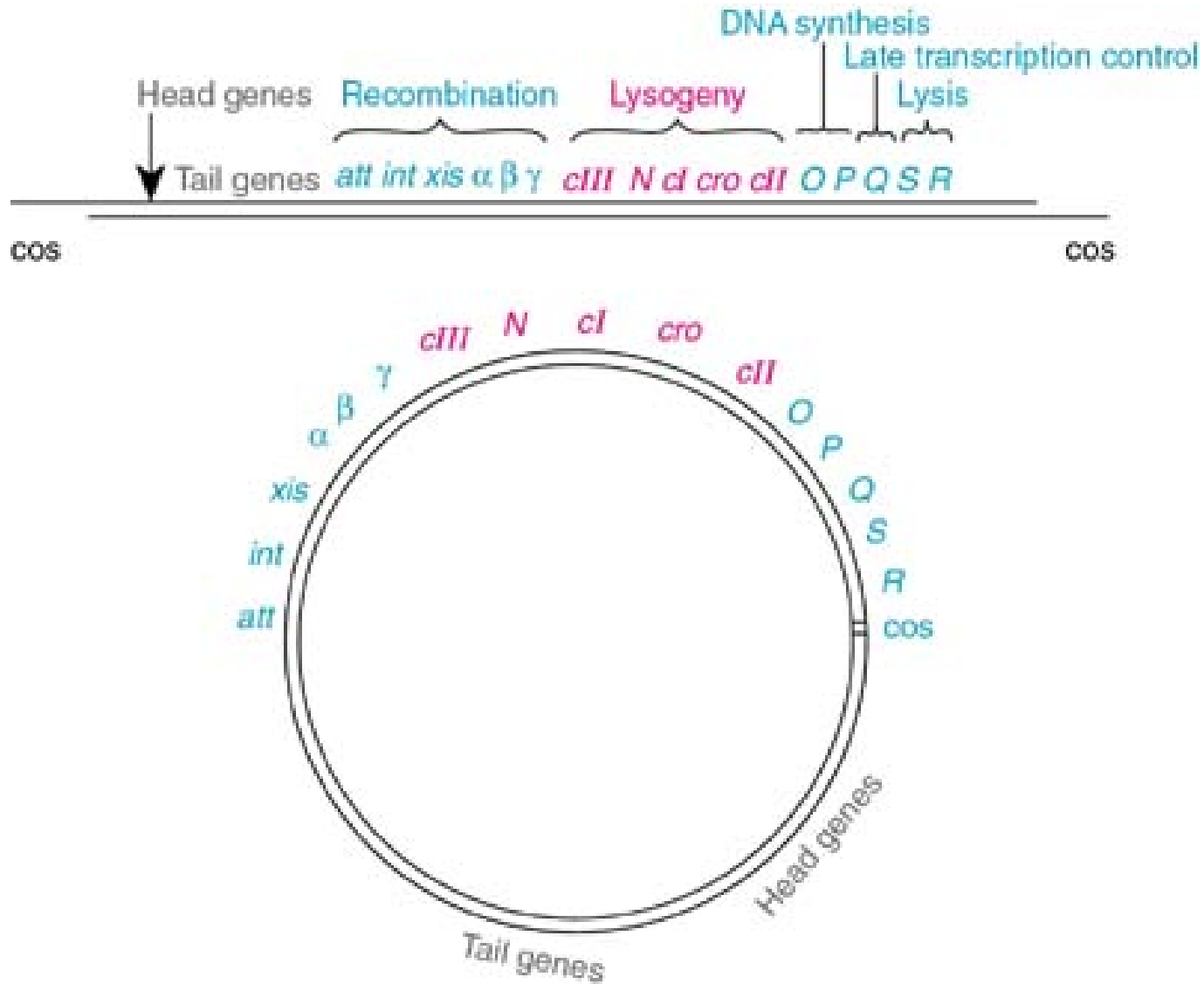

Source: <http://www.msu.edu/course/mmg/431/lambda2.html>

Bacteriophage λ

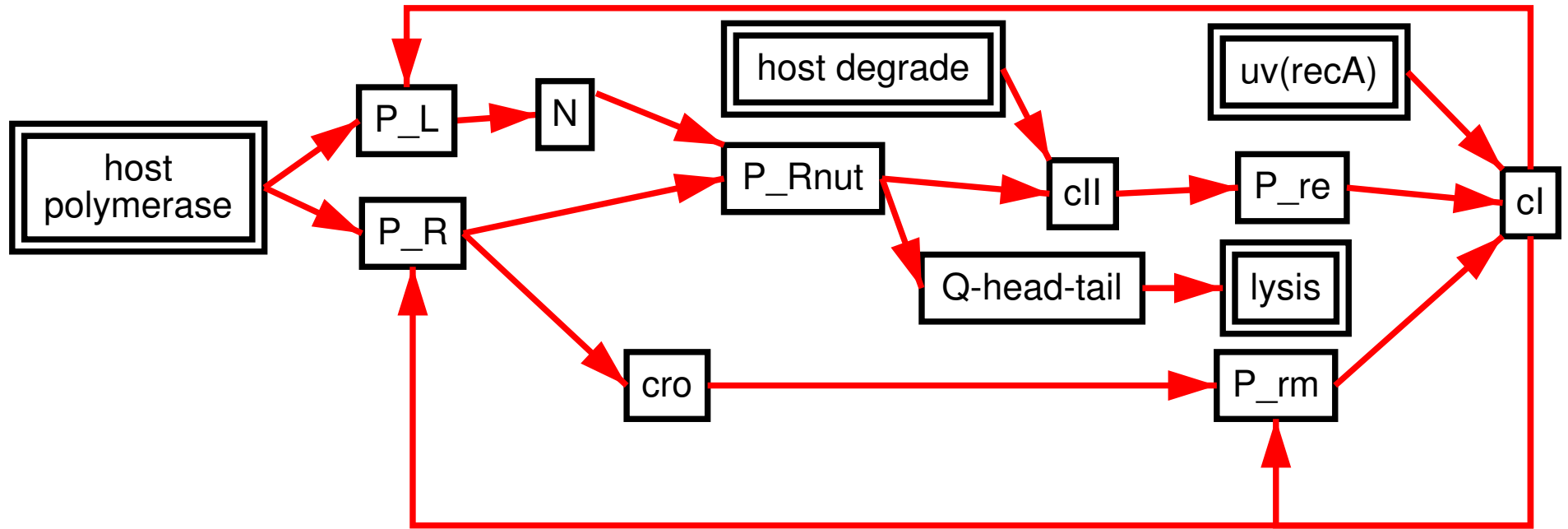

λ response to UV

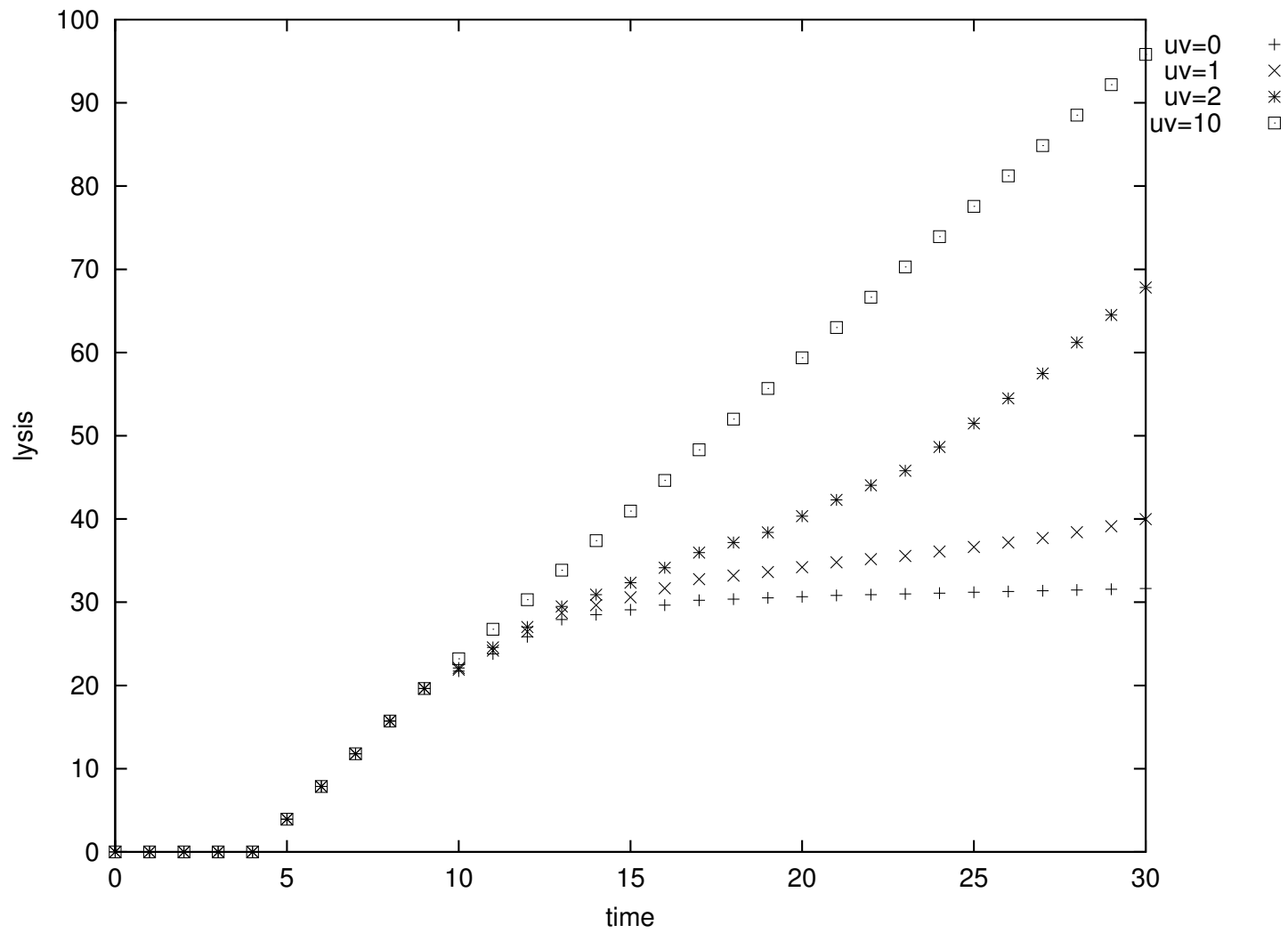

λ response to host transcription rate

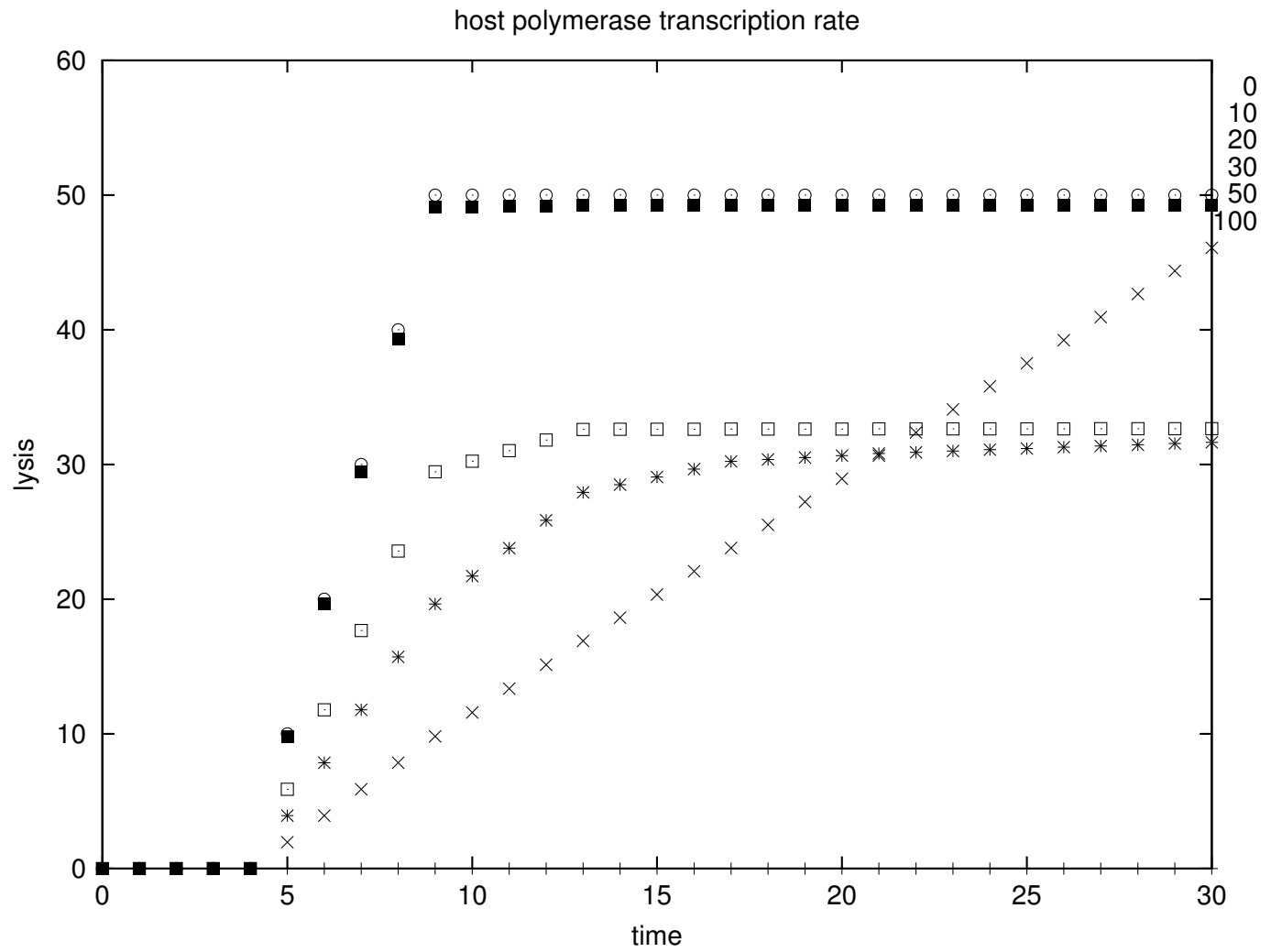

MAPK Signaling Pathway

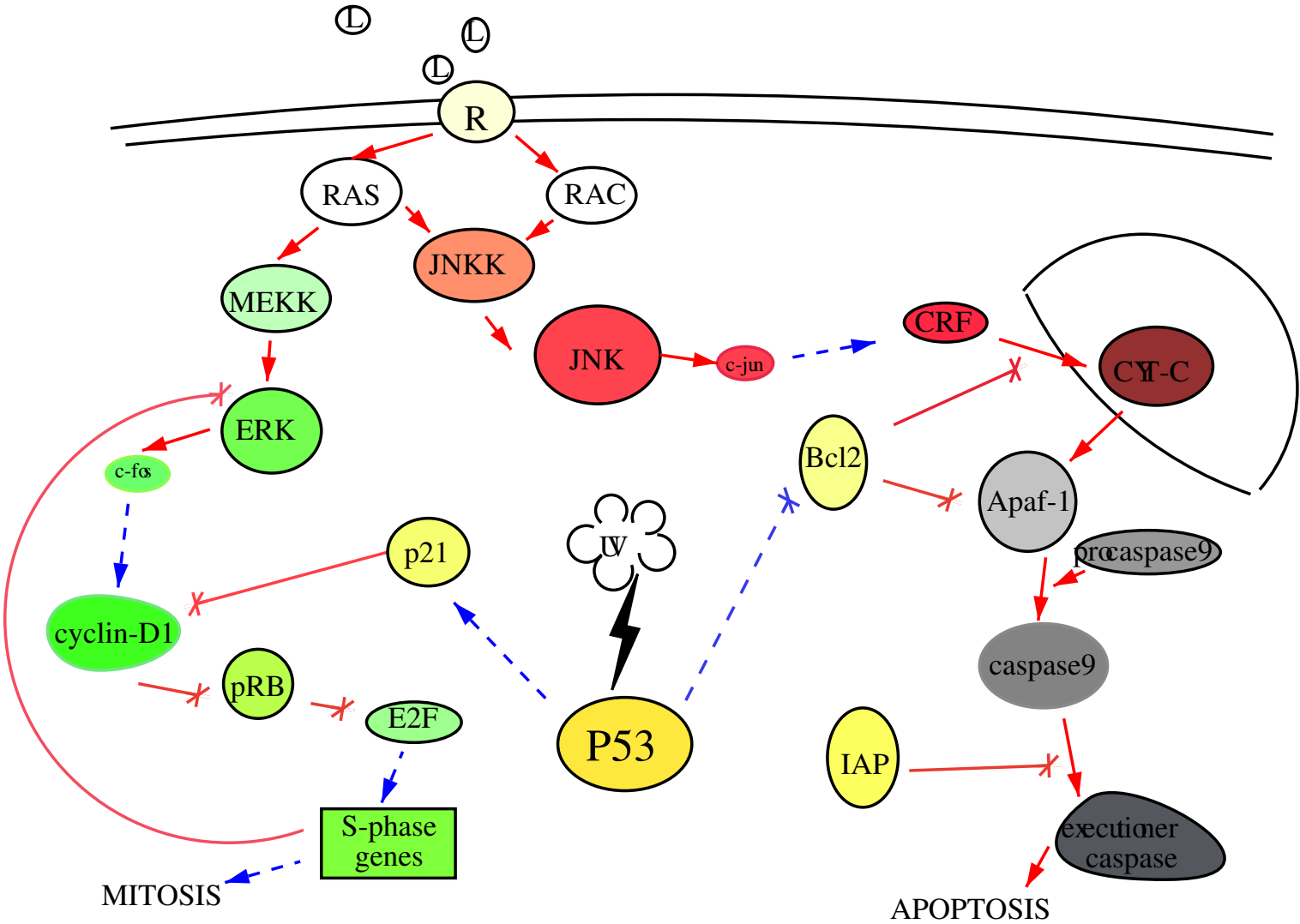

Modules in MAPK Signaling Pathway

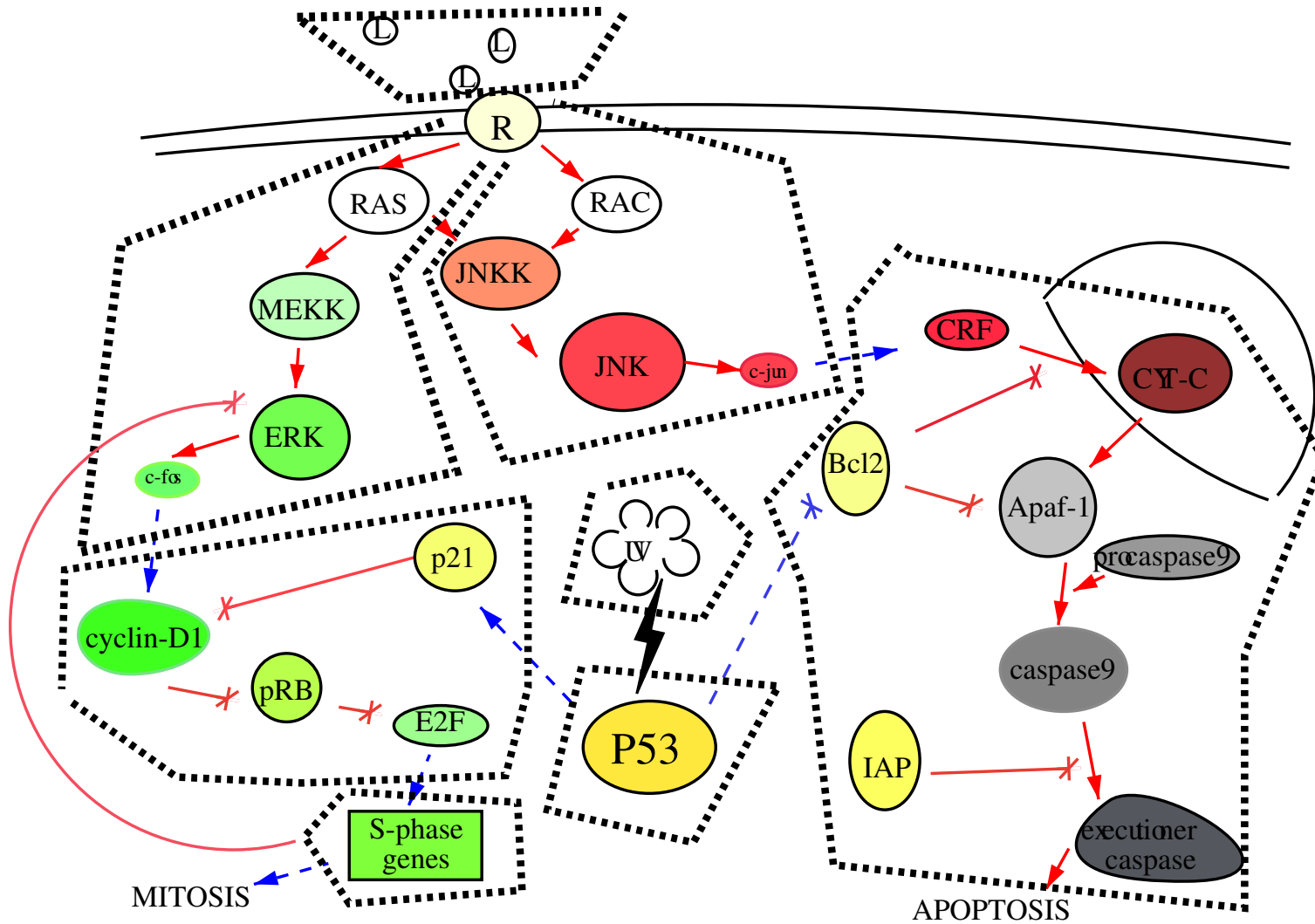

MAPK Network Model

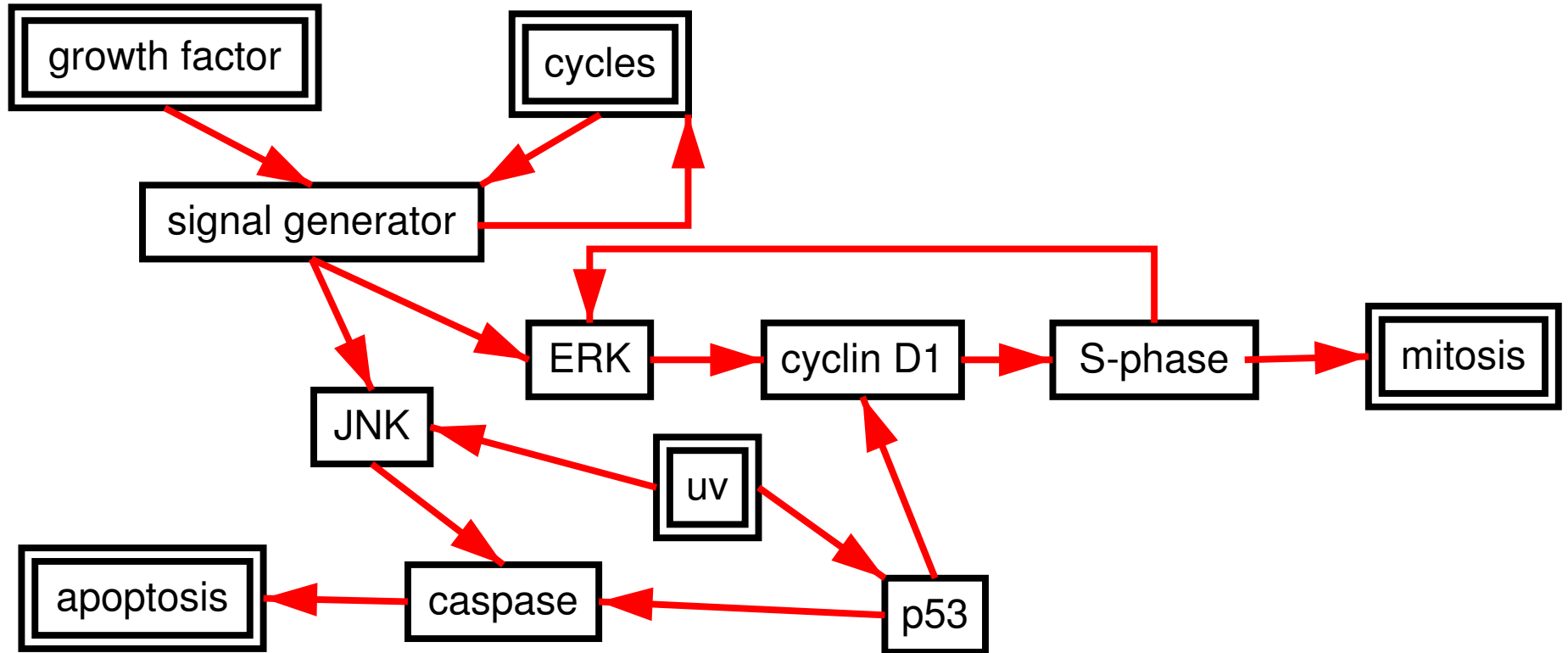

UV response of the MAPK Network

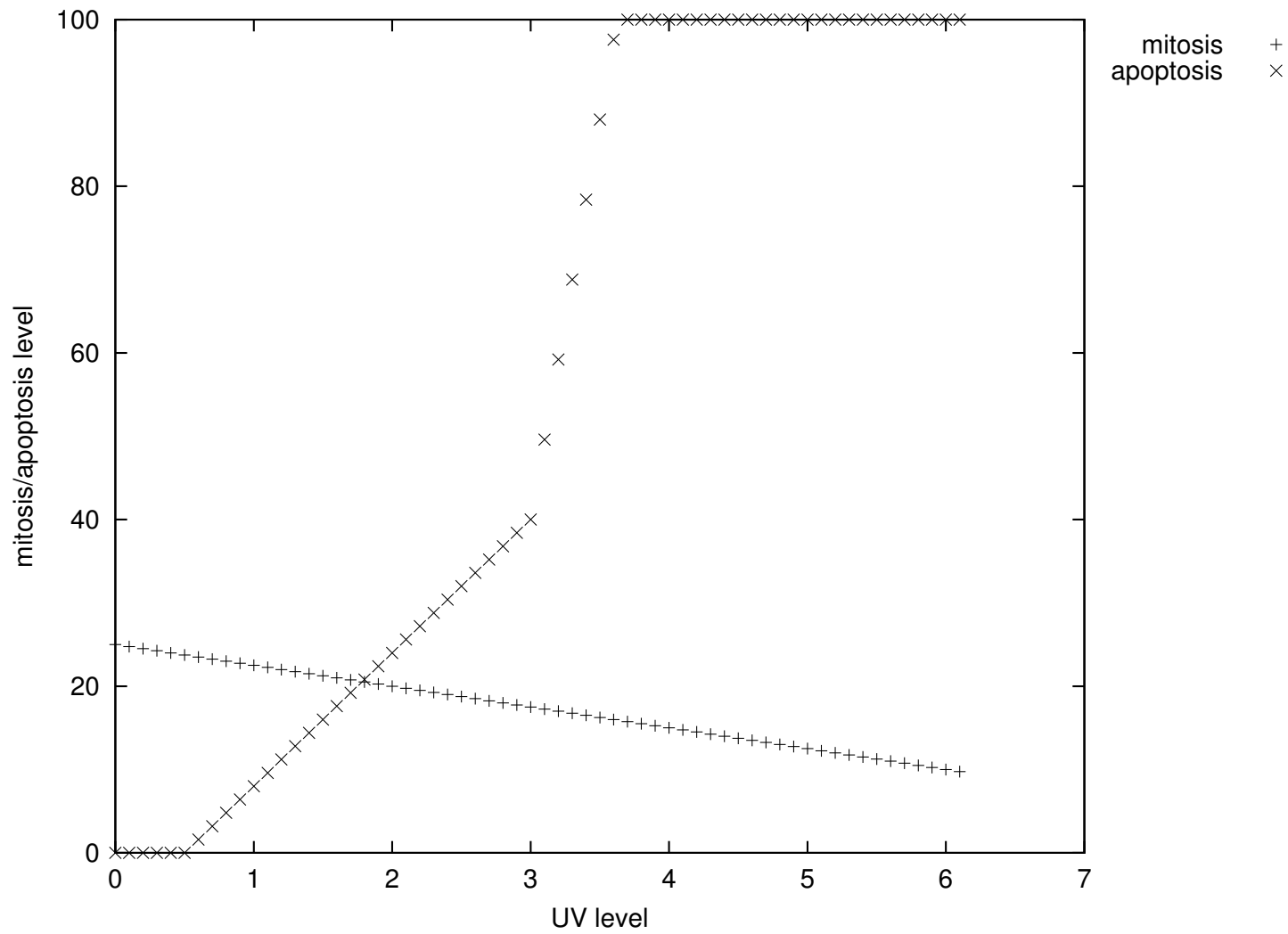

Synthetic Network: 2-bit Adder

Perform Digital addition

Modules use same transfer curves as in previous networks

- SA boxes (sum and AND)
- SR boxes (signal restoration, sigmoidal curves)
- CS (correct sum)

$$\begin{array}{r} a_2 \quad a_1 \\ + \quad b_2 \quad b_1 \\ \hline c_3 \quad c_2 \quad c_1 \end{array}$$

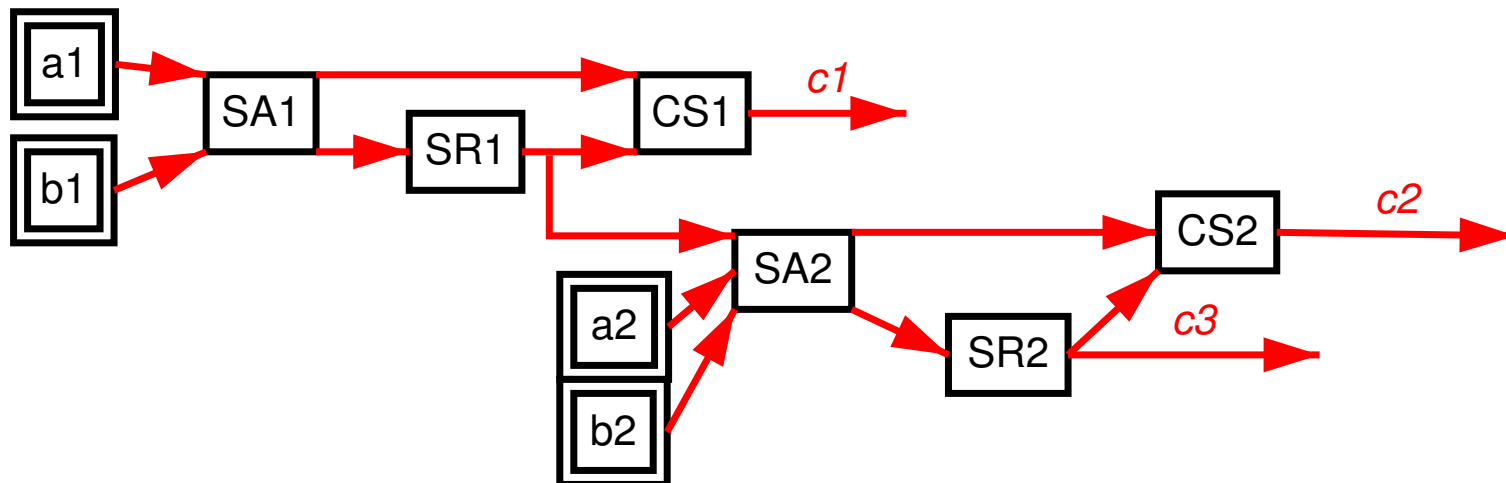

Errors in Predictions

Used the network model for λ with random transfer curves

- Average error over 100 simulations of 50 iterations each

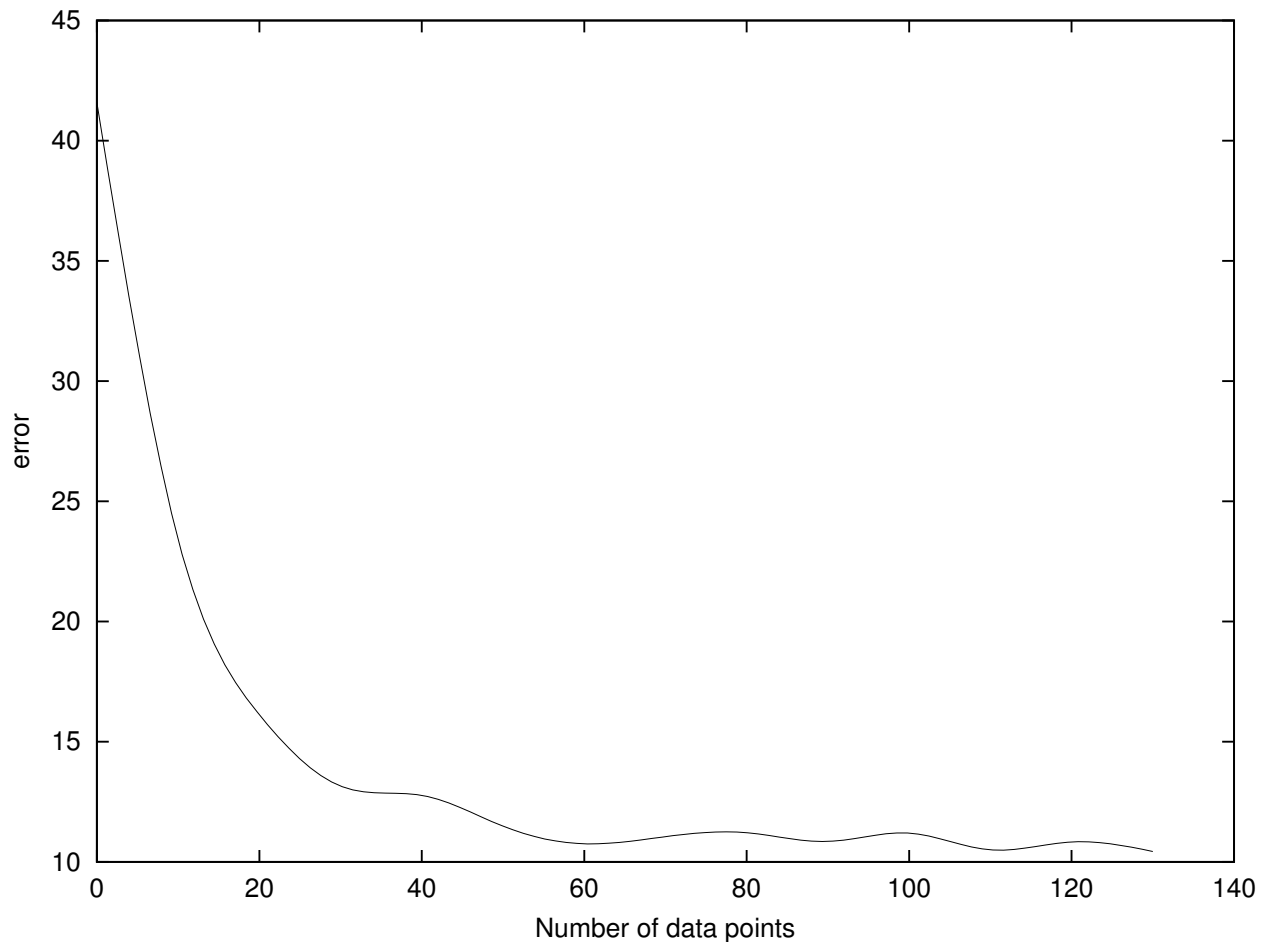

Proposed Methodology Overview

- TIPS measurement
- Library of regulatory regions
 - ▷ *Creating the library*
 - ▷ *Searching the library*
 - ▷ *Matching regulatory region strengths*

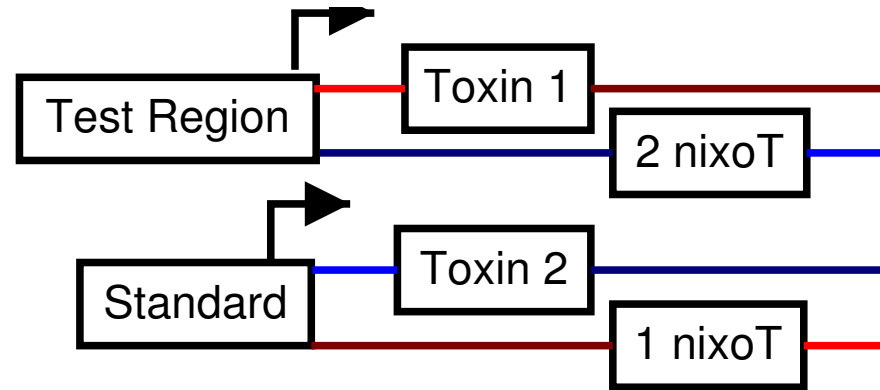

- Transfer curve measurement

Conclusions

This modeling approach works!

Tool for manipulating biological systems

Comparisons with other types of models

- *Modularity*
- High level of abstraction while still being quantitative
- Some phenomena cannot be modeled by transcription
- Time dependence can be tricky to model

Forward engineering of synthetic networks